



FLIR PTU-D48TM E-SERIES

Compact, Precise, Extremely Rugged Pan/Tilt Units

The PTU-D48 E Series supports any type of single or multi-part payload through a flexible bracketing system of top and/or side mounting. The real-time command interface supports advanced applications such as video tracking.

The PTU-D48 E Series has been proven in a wide range of mission-critical applications for positioning of cameras, lasers, antennas, or other instruments in both fixed and mobile environments. It is designed for high duty cycles and reliable operation 24/7 in harsh all-weather environments. The low parts count, and highly integrated design provides unsurpassed system reliability.

The latest evolution of FLIR pan-tilts incorporates a powerful 32-bit core electronics platform and real-time operating system to deliver superior motion control fidelity and improve performance.

KEY FEATURES INCLUDE:

- Large payload capacity to 15 Lbs
- Extremely precise positioning (to 0.006° with microstep)
- Wide range of pan speeds 0.006°/sec to 100° for smooth, precise control
- 360-continuous pan (with slip-ring option)
- Precise, real-time control of position, speed and acceleration
- Rigid worm gear design (no belts/pulleys) provides steady positioning in windy environments
- Integrated Ethernet and Web interfaces
- Increased command rates, reduced jitter
- Advanced microstep control

OPTIONS

- Payload brackets (top, side)
- Alternate colors/finishes
- Inertial stabilization
- Geo-pointing built in

Specifications

Pan/Tilt Performance	Side Mount	Top Mount
Max. Payload	15 lb	10 lb
Pan Speed Range ¹	0.006°/sec – 100°/sec	0.006°/sec – 100°/sec
Tilt Speed Range	0.003°/sec – 50°/sec	0.003°/sec – 50°/sec
Resolution – Pan	0.006°	0.006°
Resolution – Tilt	0.003°	0.003°
Pan/Tilt Features		
Tilt Range	Programmable up to +30° to -90° from level (120° range)	
Pan Range	Programmable up to +/-188° range, nx360° with slip-ring option	
Duty Cycle	Up to 100% duty cycle	
Acceleration/Deceleration	On-the-fly speed and position changes	
Power Requirements		
Input Voltage	Unregulated 12-30 VDC (fastest performance & torque @ 30 VDC)	
Input Protection	Over-voltage/over-current protection meets MIL-STD-1275D	
Power Consumption (Measured at 30 VDC)	19.8W (Low move power mode), 26.4W (Regular move power mode) 34.5W (High move power mode), 3.3W (Hold power off mode)	
Connections & Communications		
Base Connectors	PRIMARY: Connector: 32-pin (MIL-C-26482) Includes: PTU-Power (3c) - 12-30 VDC + shield PTU-Control (7c) - RS-232 (3c) and RS-485/-422 (4c) Ethernet (4c) pan/tilt configuration/control Payload Pass-Through (9-12c)	
Payload Signal Pass-Through	Power (2c): 30 VDC max. @ 3 A Video-1 (2c): NTSC/PAL/RS-170 Video-2 (2c): NTSC/PAL/RS-170 High-Speed Pass-Through (4c): capable of 10baseT Other (3c): 30 VDC max. @ 1 A Connector: 19-pin (MIL-C-26402)	
Computer Controls	RS-232, RS-485/422, Ethernet	
Control Protocols	DP (ASCII, Binary), Pelco-D (option), Nexus-compatible	
Mechanical		
PTU Weight	< 12 lbs (not including brackets)	
PTU Dimensions	10.46" (h) x 6.84" (w) x 5.45" (d) (with top bracket)	
Payload Mounting	Side and/or top	
PTU Mounting	Pedestal	
Material	Machined aluminum	
Packaging & Environmental		
Standards	IP67 Certified	
Operating Temperature ²	-30°C to 70°C (no heaters)	
Humidity	100% relative humidity, non-condensing	
Ice (Operating)	Sustained operation with 0.25" ice buildup	
Dust/Sand (Operating)	Sustained exposure to blowing dust/sand	
Wind/Rain/Fog	IP67	
Salt Spray	MIL-810G Salt Spray	
Color/Finish	Black anodized and powder-coated; custom colors/finishes available	
Shock/Vibration Certifications	MIL-STD-810G Method 514.6 Vibration, Method 516.6 Drop Test, Method 516.6 Shock	
EMI	CE Mark and FCC Part 15, Subpart B, Class A	

¹Unloaded. Maximum speed may depend on exact payload configuration and input voltage.

²Reduced speeds may be required for low temperature operation.

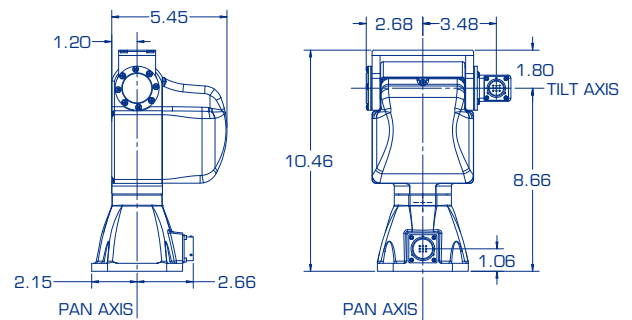

Your authorized FLIR distributor:

MOVITHERM
advanced thermography solutions

173 Technology Drive, STE 150
Irvine, CA 92618

Phone: (949) 699-6600

Email: info@movitherm.com

<http://www.movitherm.com>

CORPORATE HEADQUARTERS
FLIR Systems, Inc.
27700 SW Parkway Ave.
Wilsonville, OR 97070
PH: +1 877.773.3547

SANTA BARBARA
FLIR Systems, Inc.
6769 Hollister Ave.
Goleta, CA 93117
PH: +1 805.690.6602

CHINA
FLIR Systems Co., Ltd
Room 502, West Wing, Hanwei Building
No. 7 Guanghua Ave.
Chaoyang District, Beijing 100004, China
Phone: +86 10-59797755

EUROPE
FLIR Systems, Inc.
Luxemburgstraat 2
2321 Meer
Belgium
PH: +32 (0) 3665 5100

www.flir.com
NASDAQ: FLIR

Equipment described herein is subject to US export regulations and may require a license prior to export. Diversion contrary to US law is prohibited. Imagery for illustration purposes only. Specifications are subject to change without notice.
©2016 FLIR Systems, Inc. All rights reserved. 10/05/2016

16-0413-OEM-MCS-D48E