



FLIR *PTU-D48-ISM*[™] *E-SERIES*

Compact, Stabilized, Extremely Rugged Pan/Tilt Unit

The PTU-D48-ISM E-Series provides high-performance stabilized positioning for payloads up to 10 pounds. Stabilization improves images while on the move and allows communications links to be maintained from air, ground, or sea platforms. The PTU-D48-ISM E-Series is an ideal OEM platform for a wide range of applications including slew-to-cue, video tracking, and antenna tracking.

The PTU-D48-ISM E-Series is based on FLIR's second generation ISM stabilization platform providing superior performance. The compact, all-in-one design simplifies cabling and improves reliability. The PTU-D48 E-Series supports any type of single or multi-part payload through a flexible bracketing system of top and/or side mounting and is simple to integrate.

The latest evolution of FLIR pan-tilts incorporates a powerful 32-bit core electronics platform and real-time operating system to deliver superior motion control fidelity and improve performance.

KEY FEATURES INCLUDE:

- 3-axis, integrated gyro
- Rigid worm gear design (no belts/pulleys)
- Solid and vibration-tolerant for maritime and vehicle-mounted applications
- Wide range of pan speeds (< 0.006°/sec to 100°/sec)
- Integrated Ethernet and Web interfaces
- Increased command rates, reduced jitter
- Advanced microstep control

OPTIONS

- Payload brackets (top, side)
- Alternate colors/finishes
- Inertial stabilization
- Geo-pointing built in

Specifications

Pan/Tilt Performance	Side Mount	Top Mount
Max. Payload	10 lb	0.003°
Pan Speed Range ¹	0.006°/sec – 100°/sec	0.006°/sec – 100°/sec
Tilt Speed Range	0.003°/sec – 50°/sec	0.003°/sec – 50°/sec
Resolution – Pan	0.006°	0.006°
Resolution – Tilt	0.003°	0.003°
Pan/Tilt Features		
Tilt Range	Programmable up to +30° to -90° from level (120° range)	
Pan Range	Programmable up to +/-168° range, or 360 continuous.	
Duty Cycle	Up to 100% duty cycle	
Acceleration/Deceleration	On-the-fly speed and position changes	
Stabilization		
Type	2 Axis (3-axis, strap-down gyro, 2 stabilized axes)	
Range	Full pan-tilt range of motion	
Sine-wave Stability Error	<0.25° per axis @ 1 Hz (unloaded)	
Slew Rate	Up to pan/tilt maximum	
External Control	Accepts pan/tilt move commands while stabilized	
Power Requirements		
Input Voltage	Unregulated 12-30 VDC (fastest performance & torque @ 30 VDC)	
Input Protection	Over-voltage/over-current protection meets MIL-STD-1275D	
Power Consumption (Measured at 30 VDC)	19.8W (Low move power mode), 26.4W (Regular move power mode) 34.5W (High move power mode), 3.3W (Hold power off mode)	
Connections & Communications		
Base Connectors	PRIMARY: Connector: 32-pin (MIL-C-26482) Includes: PTU-Power (3c) - 12-30 VDC + shield PTU-Control (7c) - RS-232 (3c) and RS-485/-422 (4c) Ethernet (4c) pan/tilt configuration/control, Payload Pass-Through (9-12c)	
Payload Signal Pass-Through	Power (2c): 30 VDC max. @ 3 A, Video-1 (2c): NTSC/PAL/RS-170 Video-2 (2c): NTSC/PAL/RS-170 High-Speed Pass-Through (4c): capable of 10baseT Other (3c): 30 VDC max. @ 1 A, Connector: 19-pin (MIL-C-26402)	
Computer Controls	RS-232, RS-485/422, Ethernet	
Control Protocols	DP (ASCII, Binary), Pelco-D (option), Nexus-compatible	
Mechanical		
PTU Weight	12.4 lbs (with top bracket)	
PTU Dimensions	11.51" (h) x 6.84" (w) x 5.45" (d) (with top bracket)	
Payload Mounting	Side and/or top	
PTU Mounting	Pedestal	
Material	Machined aluminum	
Packaging & Environmental		
Standards	IP67 Certified	
Operating Temperature ²	-30°C to 70°C (no heaters)	
Humidity	100% relative humidity, non-condensing	
Ice (Operating)	Sustained operation with 0.25" ice buildup	
Dust/Sand (Operating)	Sustained exposure to blowing dust/sand	
Wind/Rain/Fog	IP67	
Salt Spray	MIL-810G Salt Spray	
Color/Finish	Black anodized and powder-coated; custom colors/finishes available	
Shock/Vibration Certifications	MIL-STD-810G Method 514.6 Vibration, Method 516.6 Drop Test, Method 516.6 Shock	
EMI	CE Mark and FCC Part 15, Subpart B, Class A	

¹Unloaded. Maximum speed may depend on exact payload configuration and input voltage.

²Reduced speeds may be required for low temperature operation.

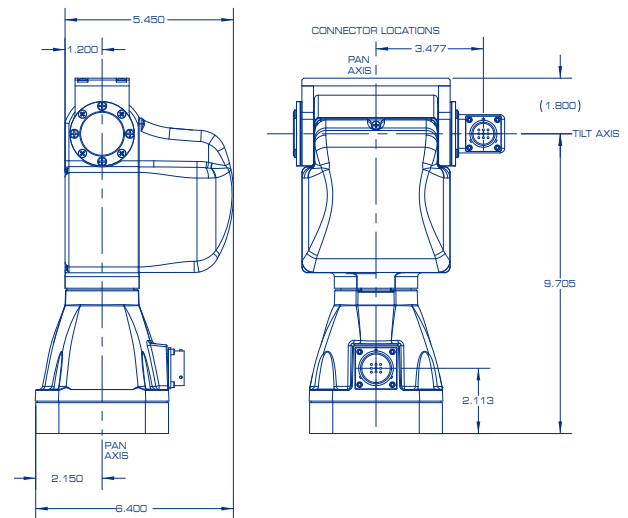

Your authorized FLIR distributor:

MOVITHERM
advanced thermography solutions

173 Technology Drive, STE 150
Irvine, CA 92618

Phone: (949) 699-6600

Email: info@movitherm.com

<http://www.movitherm.com>

CORPORATE HEADQUARTERS
FLIR Systems, Inc.
27700 SW Parkway Ave.
Wilsonville, OR 97070
PH: +1 877.773.3547

SANTA BARBARA
FLIR Systems, Inc.
6769 Hollister Ave.
Goleta, CA 93117
PH: +1 805.690.6602

CHINA
FLIR Systems Co., Ltd
Room 502, West Wing, Hanwei Building
No. 7 Guanghua Ave.
Chaoyang District, Beijing 100004, China
Phone: +86 10-59797755

EUROPE
FLIR Systems, Inc.
Luxemburgstraat 2
2321 Meer
Belgium
PH: +32 (0) 3665 5100

www.flir.com
NASDAQ: FLIR

Equipment described herein is subject to US export regulations and may require a license prior to export. Diversion contrary to US law is prohibited. Imagery for illustration purposes only. Specifications are subject to change without notice.
©2016 FLIR Systems, Inc. All rights reserved. 10/05/2016

16-0413-OEM-MCS-D48E