



# FLIR **PTU-D100**<sup>TM</sup> EX-SERIES

## Midsize, Programmable, Rugged Pan/Tilt Unit

The PTU-D100EX E Series supports any type of single or multi-part payload through a flexible bracketing system of top and/or side mounting. The real-time command interface supports advanced applications such as video tracking.

The PTU-D100EX E Series has been proven in a wide range of mission-critical applications for positioning of cameras, lasers, antennas, or other instruments in both fixed and mobile environments. It is designed for high duty cycles and reliable operation 24/7 in harsh all-weather environments. The low parts count, and highly integrated design provides unsurpassed system reliability.

The latest evolution of FLIR pan-tilts incorporates a powerful 32-bit core electronics platform and real-time operating system to deliver superior motion control fidelity and improve performance.

### **KEY FEATURES INCLUDE:**

- Large payload capacity to 25 Lbs
- Extremely precise positioning (to 0.0075° with microstep)
- Wide range of pan speeds 0.0075°/sec to 60° for smooth, precise control
- 360-continuous pan
- Precise, real-time control of position, speed and acceleration
- Rigid worm gear design (no belts/pulleys) provides steady positioning in windy environments
- Integrated Ethernet and Web interfaces
- Increased command rates, reduced jitter
- Advanced microstep control

### **OPTIONS**

- Payload brackets (top, side)
- Alternate colors/finishes
- Inertial stabilization
- Geo-pointing built in

## Specifications

Pan/Tilt Performance		D100 EX-Series	
Max. Payload <sup>1</sup>		25 lb	
Pan Speed Range <sup>2</sup>		0.0075°/sec – 60°/sec	
Tilt Speed Range <sup>2</sup>		0.0038°/sec – 50°/sec	
Resolution – Pan		0.0075° (with microstep)	
Resolution – Tilt		0.0038° (with microstep)	
Pan/Tilt Features			
Tilt Range		Programmable up to +30° to -90° from level (120° range) (up to +/-90° with side mount if specified at time of order)	
Pan Range		Programmable up to +/- 168° or 360° continuous	
100% Duty Cycle		High duty-cycle, or 3-5 million cycles	
Acceleration/Deceleration		Programmable, on-the-fly speed and position changes	
Power Requirements			
Input Voltage		Unregulated 12-30 VDC (fastest performance & torque @ 30 VDC)	
Input Protection		Over-voltage/over-current protection meets MIL-STD-1275D	
Power Consumption (Measured at 30 VDC)		33.0W (Low move power mode), 45.0W (Regular move power mode) 63.0W (High move power mode), 3.3W (Hold power off mode)	
Connections & Communications			
Base Connectors		PRIMARY: 32-pin (MIL-C-26482). Includes: PTU-Power (3c) - 9-30 VDC + shield PTU-Control RS-232/-422/-485/Ethernet (4c) pan/tilt configuration/control Payload Signals (9-13c)	
Payload Signal Pass-Through		19-pin (MIL-C-26482) includes: Power (2c): 50 VDC max @ 3 A max Video (4c): 2x Video, Serial/Aux (3-6c): RS-232/-422/-485 High-Speed Pass-Through (4c): capable of 10baseT Custom: various (optional)	
Computer Controls		RS-232, RS-485/422, Ethernet	
Control Protocols		DP (ASCII, Binary), Pelco-D (option), Nexus-compatible	
Mechanical			
PTU Weight		< 20 lb (with top bracket)	
PTU Dimensions		Pan/Tilt Only: 12.56" (h) x 7.92" (w) x 8.2" (d) (without bracket)	
Payload Mounting		Single/dual-side mount, top mount	
PTU Mounting		Pedestal	
Material		Machined & cast aluminum	
Packaging & Environmental			
Standards		IP67 Certified	
Operating Temperature <sup>3</sup>		-30°C to 70°C (no heaters)	
Humidity		100% relative humidity, non-condensing	
Ice (Operating)		Sustained operation with 0.25" ice buildup	
Dust/Sand (Operating)		Sustained exposure to blowing dust/sand	
Wind/Rain/Fog		IP67	
Salt Spray		MIL-810G Salt Spray	
Color/Finish		Black anodized; custom colors/finishes available	
Shock/Vibration Certifications		MIL-STD-810G Method 514.6 Vibration, Method 516.6 Drop Test, Method 516.6 Shock	
EMI		CE Mark and FCC Part 15, Subpart B, Class A	

<sup>1</sup>Over-the-top payload assumes COG < 6" from tilt axis; over the side payload assumes balanced COG.

<sup>2</sup>Maximum speed may depend on exact payload inertia and input voltage.

<sup>3</sup>Reduced speeds may be required for low temperature operation.

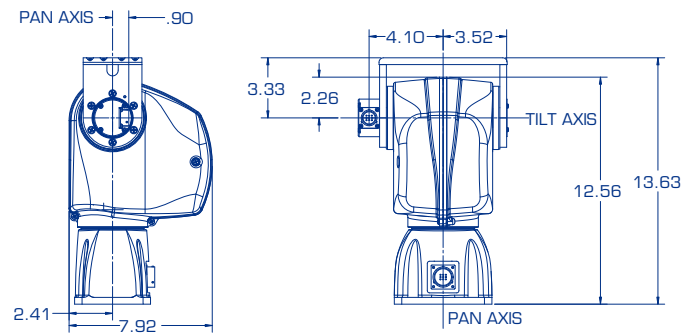

Your authorized FLIR distributor:

**MOVITHERM**  
advanced thermography solutions

173 Technology Drive, STE 150  
Irvine, CA 92618

Phone: (949) 699-6600

Email: [info@movitherm.com](mailto:info@movitherm.com)

<http://www.movitherm.com>

**CORPORATE HEADQUARTERS**  
FLIR Systems, Inc.  
27700 SW Parkway Ave.  
Wilsonville, OR 97070  
PH: +1 877.773.3547

**SANTA BARBARA**  
FLIR Systems, Inc.  
6769 Hollister Ave.  
Goleta, CA 93117  
PH: +1 805.690.6602

**CHINA**  
FLIR Systems Co., Ltd  
Room 502, West Wing, Hanwei Building  
No. 7 Guanghua Ave.  
Chaoyang District, Beijing 100004, China  
Phone: +86 10-59797755

**EUROPE**  
FLIR Systems, Inc.  
Luxemburgstraat 2  
2321 Meer  
Belgium  
PH: +32 (0) 3665 5100

www.flir.com  
NASDAQ: FLIR

Equipment described herein is subject to US export regulations and may require a license prior to export. Diversion contrary to US law is prohibited. Imagery for illustration purposes only. Specifications are subject to change without notice.  
©2016 FLIR Systems, Inc. All rights reserved. 10/06/2016

16-0413-OEM-MCS-D100EX-Series