

168LC Series

Liquid Cooled Stainless Steel Camera Housing



Installation manual

TABLE OF CONTENTS

	<i>Page</i>
DESCRIPTION	04
MODELS	04
CERTIFICATIONS	04
INSTALLING THE CAMERA	04
ABFL-01 AIR BATTERY FILTER CONNECTION TO 168LC CAMERA HOUSING	06
DIMENSIONS	07

DESCRIPTION

Hot and harsh environments require adequate equipment. The **168LC** (liquid cooled) series AISI316L stainless steel camera housing is designed to protect CCTV cameras in industrial and highly corrosive environments. The **168LC** series 168 mm internal diameter is conceived to fit medium/large size camera.

To avoid oil and dust particles and to grant clean air for the barrier, the ABFL-01 filtering battery is available as an option.

MODELS

168LC70	Camera housing (L=500mm). Usable front window: 70mm
168LC110	Camera housing (L=500mm). Usable front window: 110mm
168LCIRZ70	Camera housing (L=500mm) for IR viewings (Zinc Selenide front window)
168LCIRG70	Camera housing (L=500mm) for IR viewings (Germanium front window)



CERTIFICATIONS

Weatherproof standard: IP67

EN 61000-6-3:2007 and 50130-4:1995 + A1:1998 + A2:2003 (EMC – Electromagnetic Compatibility)

60950-1:2006 + A11:2009 (LVD – Safety)

INSTALLING THE CAMERA

	Prior to installation and operation, read carefully all instructions the in this manual and heed all warnings.
	Unpack this equipment and handle it carefully. If the package appears to be damaged, notify the shipper immediately.
	Use the original packaging to transport the unit. Disconnect power supply before moving it. In case of returning the equipment, the original packaging must be used.
	Make sure that the installation surface can support at least four times the weight of the unit in normal operating conditions. In case of excessive external stress (e.g. vibration, strong winds or impact), the equipment may need additional means of protection.
	Proper stainless steel hardware should be carefully chosen to fasten the unit to the surfaces.
	Use caution when lifting and assembling the unit. It is recommended that non-slip protective gloves be worn during installation. The unit could bear sharp edges.
	To maintain the IP rating of the unit, adequate cable glands must be used. The unit must be tightly closed when operating.
	When placed in hot environments, water must flow inside the chamber. Do not close the 1/2" GAS connectors. Failing to do so will result in serious damages for the unit. Max operating temperature: 400° C.
	Max liquid pressure: 4 bar.
	For security reasons, do not install the unit in the proximity of water containers and never push objects or pour liquids into the unit. The unit can be safely used in damp environments or outdoors, as long as the connectors are properly sealed.
	Video and data cables should not share the same conduit with supply voltage cables. Whenever EMC is an issue, adequately shielded cables must be used.
	Open only the covers pointed out in this installation manual. Other covers should be open only by the manufacturer. Tightening/loosing the screws using automatic tools such as drill drivers may result in damaged threads.
	This equipment has been designed to fit in harsh environments requiring little or no maintenance. Suggested inspection interval is 6 months, but extremely harsh environments may require more frequent inspection and maintenance checks. On each inspection check the O-ring seals and the eventual window wiper blade integrity. Replace them if necessary. Check cables, electrical connections and mounting hardware for integrity and tightness. Replace or tighten any damaged/loose part.
	Before performing any operation, turn off the power. The installation of the unit can be performed only by qualified personnel in accordance with the regulations in force. Do not connect the unit to a supply circuit unless the installation is completed.
	Check carefully the supply voltage marked on the label. Incorrect Power Supply Voltage may damage the unit. Do not overload the terminal connection, as it may cause a fire or electrical shock hazard.
	An all-pole mains switch with an opening distance between the contacts at least 3 mm in each pole must be incorporated in the electrical installation. The switch must be equipped with protection against the fault current towards the ground (differential) and the overcurrent (magnetothermal, maximum 15A). It must be very quickly recognizable and readily accessible. A suitable blow fuse must also be installed for protection.
	For connection to the mains, use a multipolar cable having minimum 3x1,5 mm ² (15 AWG). The main cable must be at least protected by an ordinary PVC sheath.
	Fasten all the cables inside the housing with cables ties or other fixing means to avoid the electrical contact with surrounding parts in case that terminal blocks screw off.
	Electrical connections (such as plugs and cords) must be protected from potential hazardous environmental factors (e.g. foot traffic, hitting objects).
	Ensure that the unit case is properly earthed, connecting all the earth ground studs. Earth cable should be about 10mm longer than the other cables on the connector, in such way that it won't be accidentally disconnected if the cable is stretched or pulled.
When leaving the unit unused for long periods, disconnect supply cables.	

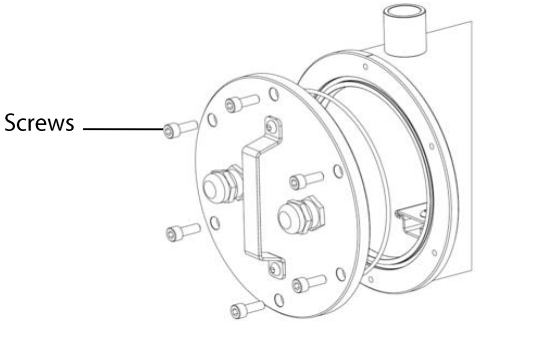
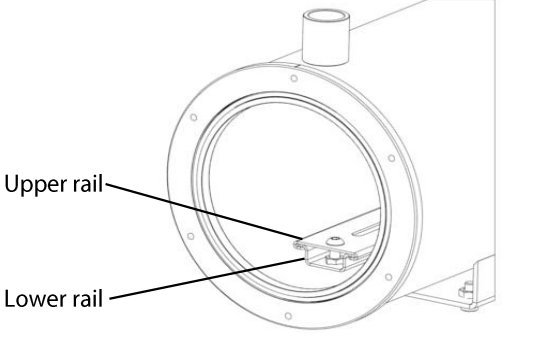
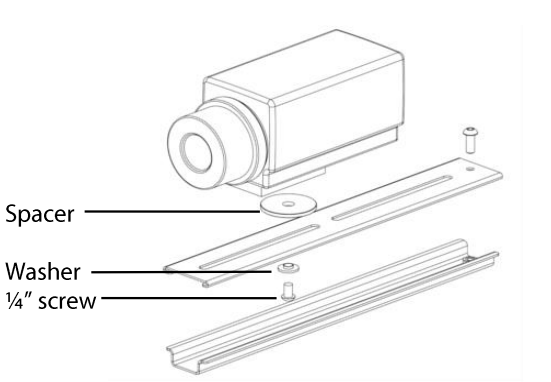
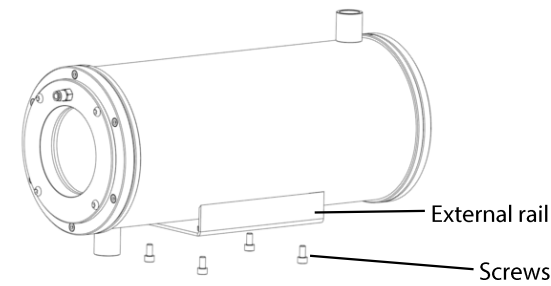
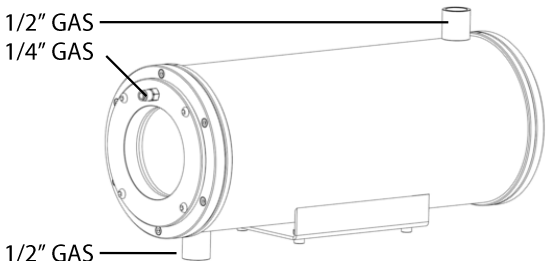
<p>1. Open the housing Unscrew the six screws on the rear flange and remove it. <u>Be careful not to lose screws, washers and O-rings.</u></p>	 <p>Screws</p>
<p>2. Prepare the housing to install the camera, sliding the upper rail away from the lower rail.</p>	 <p>Upper rail Lower rail</p>
<p>3. Install the camera Mount the camera on the internal rail using one of the 1/4" screws supplied and the plastic washer. Use the included spacers to adjust its height position. Slide the upper rail back on the lower rail into the housing Feed the cables through the cable glands on the rear flange and perform electrical and video connections according to the instructions in the camera installation manual. Check the proper position of the seal in its groove on the rear flange. Tighten the cable glands up till an 8 Nm torque ratio. Close the housing tightening the six screws on the rear flange to the main body.</p>	 <p>Spacer Washer 1/4" screw</p>
<p>4. Use the screws at the bottom of the housing to fasten the housing to its proper support.</p>	 <p>External rail Screws</p>
<p>5. Perform hydraulic and air connections. The liquid cooling system uses 2 1/2" GAS connectors welded on the external tube. The air cooling system uses a 1/4" GAS connector with 8 mm tube diameter on the front flange. Preferably water should flow in from the connector at the bottom of the housing.</p>	 <p>1/2" GAS 1/4" GAS 1/2" GAS</p>

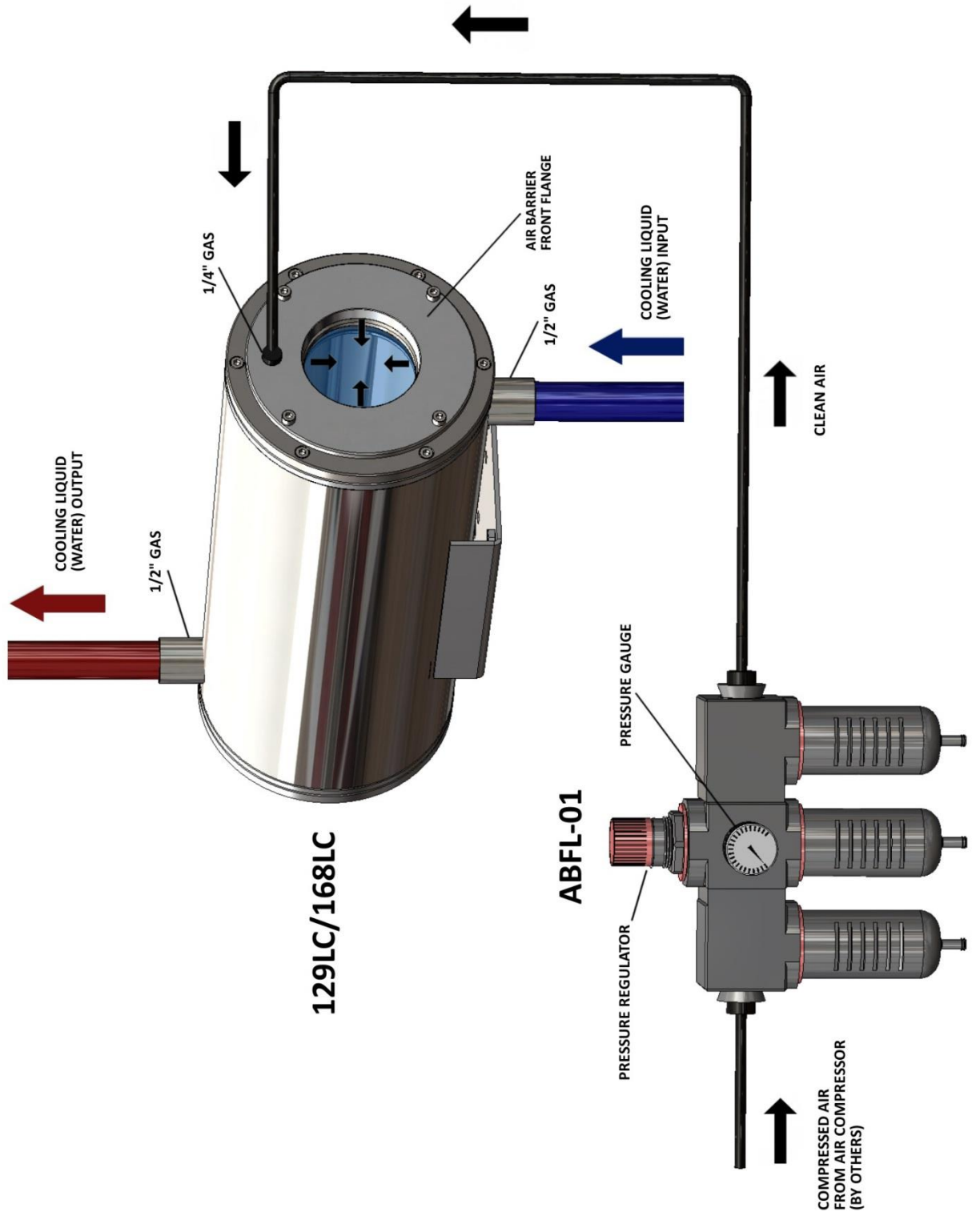

DIMENSIONS

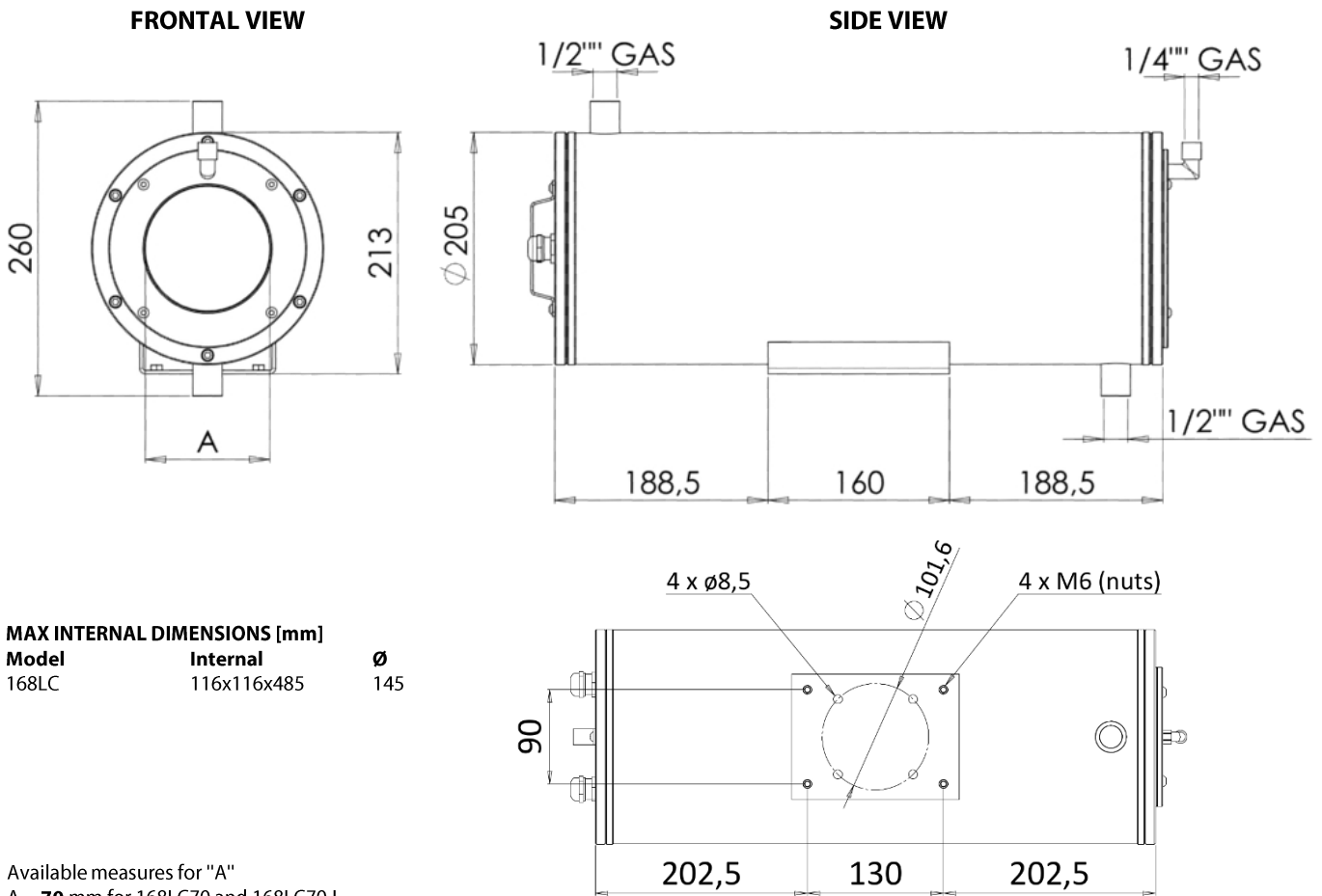

MAX INTERNAL DIMENSIONS [mm]

Model	Internal	Ø
168LC	116x116x485	145

Available measures for "A"

A = **70** mm for 168LC70 and 168LC70-L

A = **110** mm for 168LC110 and 168LC110-L

A = **70** mm for 168IR70LC and 168IR70LC-L (Zinc Selenide window)

Dimensions in millimetres – Tolerances according QMS – Design and product specifications subject to change without notice

Your authorized TECNOVIDEO distributor:

MOVITHERM
advanced thermography solutions

15540 Rockfield Blvd, Suite C-110
Irvine, CA 92618

Phone: (949) 699-6600

Fax: (949) 699-6601

Email: info@movitherm.com

<http://www.movitherm.com>



Preserve this manual as a reference for future needs.

Here you can find the always up-to-date pdf version of this document:

	<p>Used electrical, electronic and stainless steel products should not be mixed with general waste. For proper treatment, recovery and recycling of old products, please take them to applicable collection points, in accordance with your national legislation and the Directives 2002/95/EC and 2002/96/EC. By disposing of these products correctly, you will help to save valuable resources and prevent any potential negative effects on human health and the environment which could otherwise arise from inappropriate waste handling. For more information about collection and recycling of old products, please contact your local municipality or your waste disposal service. Penalties may be applicable for incorrect disposal of this waste, in accordance with national legislation.</p>
---	--

The manufacturer declines all liability for any consequence resulting from improper installation practices, tampering or improper uses of the product.

The descriptions and illustrations contained in this manual are not binding. The manufacturer reserves the right to make any alterations deemed appropriate for the technical, manufacturing and commercial improvement of the product, while leaving the essential product features unchanged, at any time and without undertaking to update the present publication.

TECNOVIDEO S.r.l.

Via San L. Murialdo, 8 36030 Villaverla (VI) ITALY

Tel. +39.0445.350444 Fax +39.0445.357259

e-mail: info@tecnovideocctv.com – www.tecnovideocctv.com