

# 129 Series

**Medium size Stainless Steel Camera Housing**



## **Installation manual**

## DESCRIPTION

The **129 series** is entirely made in AISI316L stainless steel to protect CCTV cameras in outdoor locations, especially where corrosive environment can cause the premature deterioration of a standard aluminium/plastic camera housing.

## MODELS

<b>129</b>	Camera housing (L=360 mm)
<b>129SH</b>	Camera housing (L=360 mm) with sunshield and heater
<b>129WW</b>	Camera housing (L=360 mm) with sunshield, heater and integrated wiper
<b>129AB</b>	Camera housing (L=360 mm) with front window air barrier. Sunshield and heater optional
<b>129IR50</b>	Camera housing (L=360 mm). UFW: 50 mm
<b>129SHIR50</b>	Camera housing (L=360 mm) with sunshield and heater. UFW: 50 mm
<b>129WWIR50</b>	Camera housing (L=360 mm) with sunshield, heater and integrated wiper. UFW: 50 mm
<b>129IR70</b>	Camera housing (L=360 mm). UFW: 70 mm
<b>129SHIR70</b>	Camera housing (L=360 mm) with sunshield and heater. UFW: 70 mm
<b>129WWIR70</b>	Camera housing (L=360 mm) with sunshield, heater and integrated wiper. UFW: 70 mm
<b>129ABIR70</b>	Camera housing (L=360 mm) with front window air barrier. Sunshield and heater optional. UFW: 70 mm

**UFW:** usable front window diameter  
**-L** suffix refers to camera housing with L=460 mm

## CERTIFICATIONS

Weatherproof standard: IP67

EN 61000-6-3:2007 and 50130-4:1995 + A1:1998 + A2:2003 (EMC – Electromagnetic Compatibility)

60950-1:2006 + A11:2009 (LVD – Safety)

## INSTALLING THE CAMERA

	Prior to installation and operation, read carefully all instructions the in this manual and heed all warnings.
	Unpack this equipment and handle it carefully. If the package appears to be damaged, notify the shipper immediately.
	Use the original packaging to transport the unit. Disconnect power supply before moving it. In case of returning the equipment, the original packaging must be used.
	Make sure that the installation surface can support at least four times the weight of the unit in normal operating conditions. In case of excessive external stress (e.g. vibration, strong winds or impact), the equipment may need additional means of protection.
	Proper stainless steel hardware should be carefully chosen to fasten the unit to the surfaces.
	Use caution when lifting and assembling the unit. It is recommended that non-slip protective gloves be worn during installation. The unit could bear sharp edges.
	Trying to manually force the wiper will result in damaging the device and will void the warranty.
	To maintain the IP rating of the unit, adequate cable glands must be used. The unit must be tightly closed when operating.
	For security reasons, do not install the unit in the proximity of water containers and never push objects or pour liquids into the unit. The unit can be safely used in damp environments or outdoors, as long as the connectors are properly sealed.
	Video and data cables should not share the same conduit with supply voltage cables. Whenever EMC is an issue, adequately shielded cables must be used.
	Open only the covers pointed out in this installation manual. Other covers should be open only by the manufacturer. Tightening/loosing the screws using automatic tools such as drill drivers may result in damaged threads.
	This equipment has been designed to fit in harsh environments requiring little or no maintenance. Suggested inspection interval is 6 months, but extremely harsh environments may require more frequent inspection and maintenance checks. On each inspection check the O-ring seals and the eventual window wiper blade integrity. Replace them if necessary.
	Check cables, electrical connections and mounting hardware for integrity and tightness. Replace or tighten any damaged/loose part.
	Operating temperature: -20° +55° C (-4° +131° F).
	Before performing any operation, turn off the power. The installation of the unit can be performed only by qualified personnel in accordance with the regulations in force. Do not connect the unit to a supply circuit unless the installation is completed.
	Check carefully the supply voltage marked on the label. Incorrect Power Supply Voltage may damage the unit. Do not overload the terminal connection, as it may cause a fire or electrical shock hazard.
	An all-pole mains switch with an opening distance between the contacts at least 3 mm in each pole must be incorporated in the electrical installation. The switch must be equipped with protection against the fault current towards the ground (differential) and the overcurrent (magnetothermal, maximum 15A). It must be very quickly recognizable and readily accessible. A suitable blow fuse must also be installed for protection.
	For connection to the mains, use a multipolar cable having minimum 3x1,5 mm <sup>2</sup> (15 AWG). The main cable must be at least protected by an ordinary PVC sheath.
	Fasten all the cables inside the housing with cables ties or other fixing means to avoid the electrical contact with surrounding parts in case that terminal blocks screw off.
	Electrical connections (such as plugs and cords) must be protected from potential hazardous environmental factors (e.g. foot traffic, hitting objects).
Ensure that the unit case is properly earthed, connecting all the earth ground studs. Earth cable should be about 10mm longer than the other cables on the connector, in such way that it won't be accidentally disconnected if the cable is stretched or pulled.	
When leaving the unit unused for long periods, disconnect supply cables.	

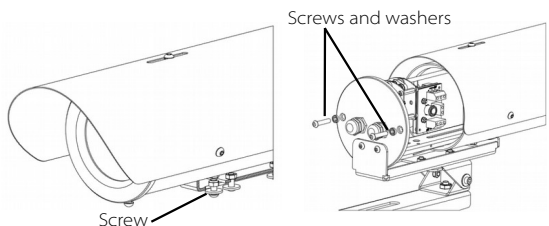
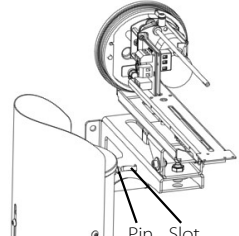
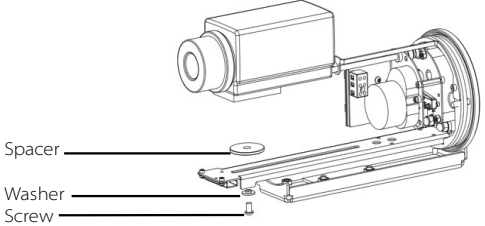
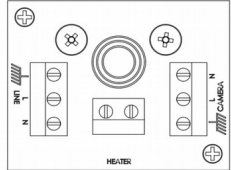
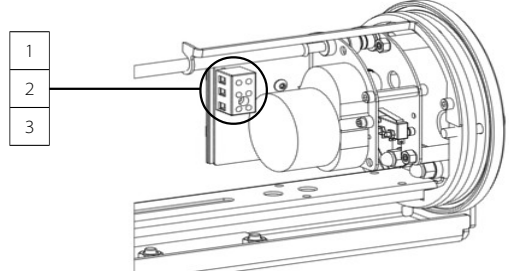
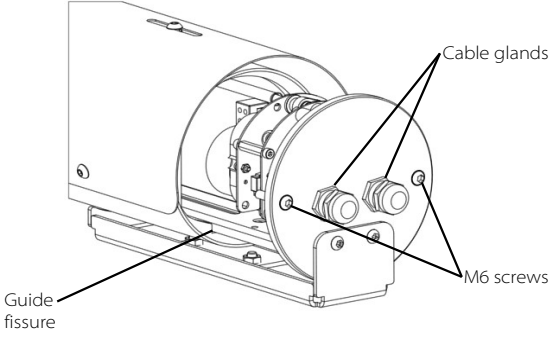
<p><b>1. Open the housing</b></p> <p>a. Loosen the screw at the bottom of the external rail. The screw is fixed to a nut welded on the housing.</p> <p>b. Unscrew the two M6 screws on the rear flange.</p> <p>c. Slide the housing outer body away from the back flange.</p> <p><u>Be careful not to lose screws, washers and O-rings.</u></p>	
<p>2. Hang the housing body inserting the pin into the slot on the bracket in order to perform electrical connections and maintenance tasks inside the housing.</p>	
<p><b>3. Install the camera</b></p> <p>Mount the camera on the internal rail using one of the 1/4" screws supplied and the plastic washer. Use the included spacers to adjust its height position. Feed the cables through the cable glands on the rear flange and perform electrical and video connections according to the instructions in the camera installation manual.</p>	
<p><b>4. Only on housings with heater system</b></p> <p>Perform the input and output (to the camera) voltage connections using the PCB installed inside the housing near the rear flange.</p>	
<p><b>5. Only on housings with wash wiper system [24/240VAC]</b></p> <p>Connect correct supply voltage between pin 1 (line) and pin 2 (neutral).</p> <p>Connecting pin 1 (line) to pin 3, the wiper works until pin 3 is disconnected, then the wiper parks itself to its initial position.</p> <p>A normally open switch, connected between pin1 and pin3, can be used for this operation.</p> <p><b><u>Only on housings with wash wiper system [24VDC]</u></b></p> <p>Connect correct supply voltage between pin 1 (GND) and pin 2 (+24V).</p> <p>Connecting pin 1 (GND) to pin 3, the wiper works until pin 3 is disconnected, then the wiper parks itself to its initial position.</p> <p>A normally open switch, connected between pin1 and pin3, can be used for this operation.</p>	
<p><b>6. Close the housing.</b></p> <p>a. Slide the housing outer body along the internal rail. The internal rail is to be inserted in the guide fissure as shown in the picture.</p> <p>Check the proper position of the seal in its groove on the rear flange.</p> <p>b. Tighten the cable glands up till an 8 Nm torque ratio.</p> <p>c. Tighten the two M6 on the rear flange screws to the main body.</p> <p>d. Fix the screw at the bottom of the external rail to the nut welded on the housing.</p>	

## DIMENSIONS

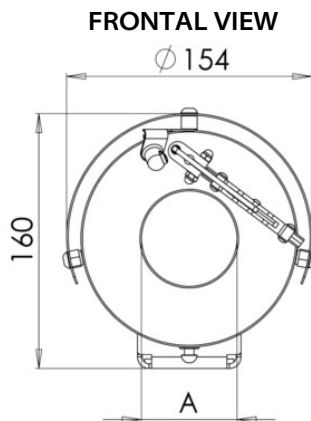

**SIDE VIEW**



### MAX INTERNAL DIMENSIONS [mm]

Model	Internal	Ø	
129/129AB/129IRXX	81x81x319	96	
129-L/129IRXX-L	81x81x419	96	
129SH/129SHIRXX	81x81x270	96	
129SH-L/129SHIRXX-L	81x81x370	96	
129WW/129WWIRXX	81x81x215	96	
129WW-L/129WWIRXX-L	81x81x315	96	

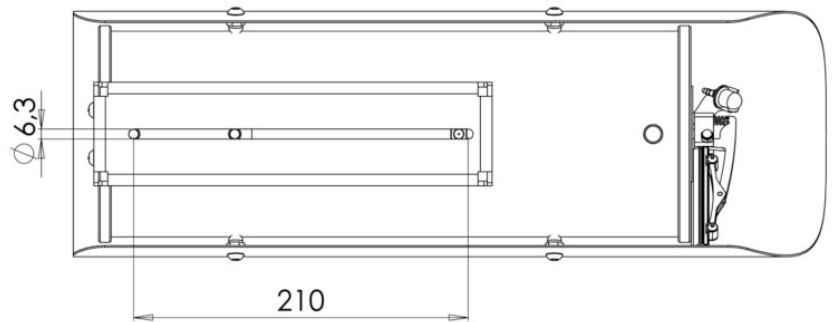

Dimensions in brackets refer to models 129-L

Available measures for "A"

A = **90** mm for 129, 129-L, 129SH and 129SH-L

A = **72** mm for 129WW and 129WW-L

A = **70** mm for 129IR70 models (germanium window) and 129AB

A = **50** mm for 129IR50 models (germanium window)

Dimensions in millimetres – Tolerances according QMS – Design and product specifications subject to change without notice



Preserve this manual as a reference for future needs.

Here you can find the always up-to-date pdf version of this document:

	<p>Used electrical, electronic and stainless steel products should not be mixed with general waste. For proper treatment, recovery and recycling of old products, please take them to applicable collection points, in accordance with your national legislation and the Directives 2002/95/EC and 2002/96/EC. By disposing of these products correctly, you will help to save valuable resources and prevent any potential negative effects on human health and the environment which could otherwise arise from inappropriate waste handling. For more information about collection and recycling of old products, please contact your local municipality or your waste disposal service. Penalties may be applicable for incorrect disposal of this waste, in accordance with national legislation.</p>
--	--

The manufacturer declines all liability for any consequence resulting from improper installation practices, tampering or improper uses of the product.

The descriptions and illustrations contained in this manual are not binding. The manufacturer reserves the right to make any alterations deemed appropriate for the technical, manufacturing and commercial improvement of the product, while leaving the essential product features unchanged, at any time and without undertaking to update the present publication.

Your authorized **TECNOVIDEO** distributor:

**MOVITHERM**  
advanced thermography solutions  
15540 Rockfield Blvd, Suite C-110  
Irvine, CA 92618

Phone: (949) 699-6600  
Fax: (949) 699-6601  
Email: [info@movitherm.com](mailto:info@movitherm.com)  
<http://www.movitherm.com>

**TECNOVIDEO S.r.l.**

Via San L. Murialdo, 8 36030 Villaverla (VI) ITALY  
Tel. +39.0445.350444 Fax +39.0445.357259  
e-mail: [info@tecnovideocctv.com](mailto:info@tecnovideocctv.com) – [www.tecnovideocctv.com](http://www.tecnovideocctv.com)