

TECNOVIDEO

CCTV SYSTEMS AND ACCESSORIES

168LC SERIES

STAINLESS STEEL CAMERA STATION

SAFE AREA

AISI316L STAINLESS STEEL CONSTRUCTION
FOR USE IN HIGHLY CORROSIVE ENVIRONMENTS
EASY INSTALLATION AND MAINTENANCE
LIQUID COOLING SYSTEM
WEATHERPROOF STANDARD IP66/IP67
SUITABLE FOR ANALOG AND IP CAMERAS
DAY/NIGHT AND IR THERMAL VERSIONS AVAILABLE
REFINED AND MODERN DESIGN



168LC LIQUID COOLED CAMERA HOUSING

TECHNICAL SPECIFICATIONS

GENERAL & MECHANICAL

Dimensions	See drawings next page
Operating Temperature	See "Temperature" section
Construction	AISI316L Stainless Steel
Finish	Electro-polished
Mounting	See drawings next page
Cable entries	2 M20x1,5 threaded holes. Cable glands not included

Weight		
Model	Unit [kg]	Package [kg]
168LC/168LCIR	18	20

TEMPERATURE

Borosilicate glass window (housing model 168LC70 and 168LC110)

Temperature [°C]		Temperature [°F]	
External	Internal	External	Internal
200	23	392	74
300	33	572	92
400	45	752	113

Zinc Selenide window (housing model 129LCIRZ70)

Temperature [°C]		Temperature [°F]	
External	Internal	External	Internal
200	23	392	74
300	33	572	92

Temperatures may differ depending on environmental factors, water flow and air flow. Internal tests performed using ~6 l/min [-1,59 US gal/min] water flow and ~6 bar air pressure in front air barrier

CERTIFICATIONS

Ingress Protection(EN 60529)	IP66/IP67
EMC	EN 61000-6-3:2007; EN 50130-4:1995 + A1:1998 + A2:2003
LVD	EN 60950-1:2006 + A11:2009
RoHS	2011/65/EU
WEEE	2012/19/EU

MODELS

168LC70¹	Liquid cooled camera housing. UW:70
168LC110¹	Liquid cooled camera housing. UW:110
168LCIRG70²	Liquid cooled camera housing. UW:70
168LCIRZ70³	Liquid cooled camera housing. UW:70

¹	UW= Usable front window diameter. Thickness: 5 mm. Borosilicate glass (Borofloat), with high chemical resistance and low thermal expansion
²	UW= Usable front window diameter. Thickness: 3 mm. Germanium, AR/DLC coating. Recommended environmental temperature not above 100°C/212°F
³	UW= Usable front window diameter. Thickness: 5 mm. Zinc Selenide with AR/AR coating

MOUNTING ACCESSORIES

SSBK168LC	Wall mounting bracket with swivel joint for 168LC Series
SSPM168LC	Pole mount adapter for SSBK168LC

ACCESSORIES AND SPARE PARTS

MK168LC	Maintenance kit with Viton O-ring seals, screws seals, screws, desiccant bags
ABFL-01	Air filtering battery 20 – 5 – 0.1 micron (for air barrier front flange)

DIMENSIONS

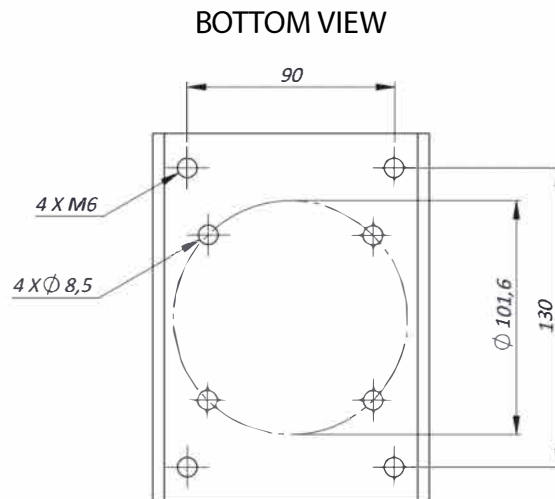
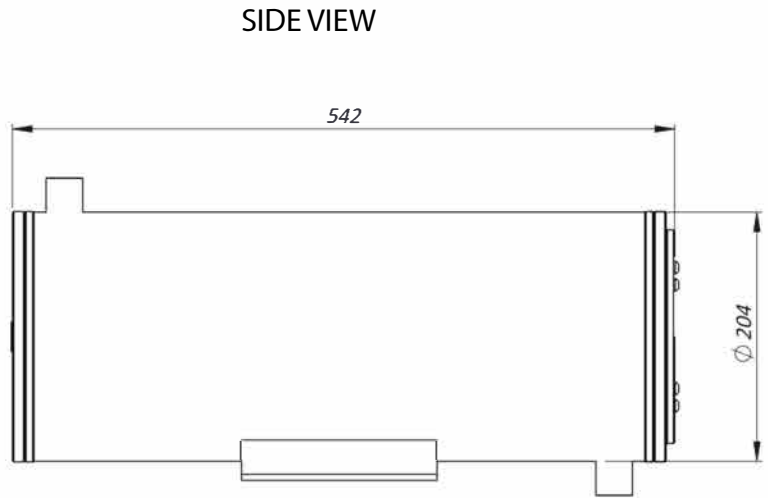
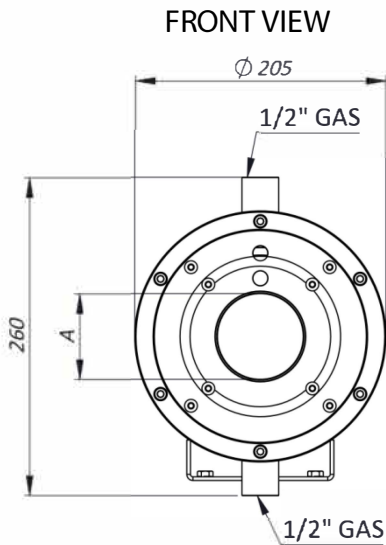

Your authorized TECNOVIDEO distributor:

MOVITHERM

advanced thermography solutions

15540 Rockfield Blvd, Suite C-110

Irvine, CA 92618

Phone: (949) 699-6600

Fax: (949) 699-6601

Email: info@movitherm.com

<http://www.movitherm.com>

FOR "A" VALUES CHECK "MODELS" SECTION

MAX INTERNAL USABLE AREA

Model	Max internal dimensions [mm]	Max usable internal diameter [mm]
168LC/168LCIR	116x116x445	145