

This *Configuration Guide* lists the configuration options and accessories for the PTU-D300 E Series pan-tilt units with the optional ISM (PTU-D300E-ISM) manufactured by FLIR Motion Control Systems, Inc. Additional information and instructions for the PTU-D300E-ISM are available in the following documents:

- PTU-D300 E Series *Datasheet*
- PTU-D300 E Series *User Manual*
- Pan-Tilt Unit (E Series) *Command Reference Manual*
- *ISM User Manual*

## Model Numbers

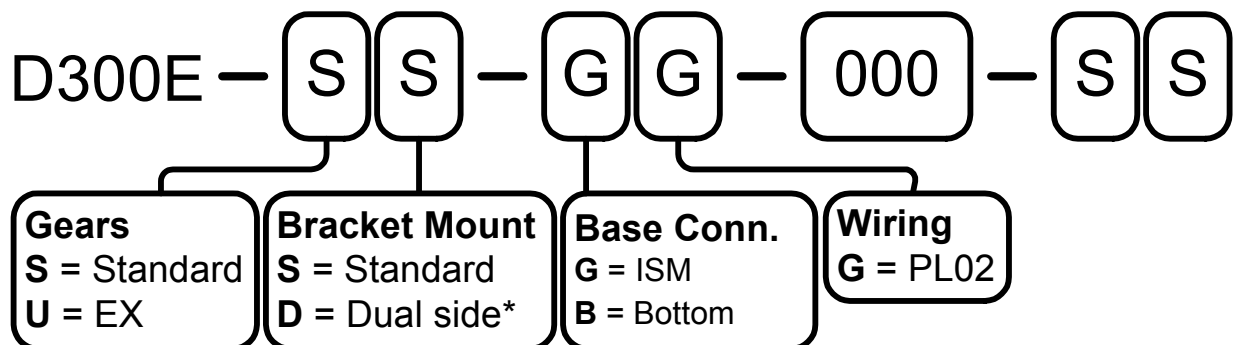

\* = Dual side hubs, with top bracket installed

## Available Options

The following configuration and options are available for the PTU-D300E-ISM:

- **EX Gears:** The PTU-D300E-ISM with EX gears provides additional torque with slower axis speeds for heavier loads. Page 2.
- **Bracket Mount:** Payloads can be mounted on the top and/or side. A number of bracket options are available to suit each application. Page 2.
- **Bottom Base Connector:** The PTU-D300E-ISM can be configured with the base connector located on the bottom of the unit, which is useful for pole-mounted applications. Page 3.
- **Slip Ring:** The PTU-D300E-ISM includes a slip ring for continuous 360° panning. Page 3.
- **Wiring:** The PTU-D300E-ISM includes PL02 wiring. Page 3.
- **Range of Motion:** If needed, you may request special limits. Page 4.
- **Pan-Tilt Controls:** The PTU-D300E-ISM can be controlled using an ASCII command set, Ethernet/web connection, Pelco D protocol, external joystick, or binary command set. Page 5.
- **Accessories:** Available accessories include cables, converters, power supplies, and starter kits. Page 6.

## EX Gears

The PTU-D300E-ISM with EX gears increases the maximum payload rating from 35 lbs. to 60 lbs. (top mount) or from 60 lbs. to 90 lbs. (side mount) by providing additional torque at reduced axis speeds.

**Part Number:** D300E-S-\_\_-000-SS (standard gears) or  
D300E-U-\_\_-000-SS (EX gears)

## Bracket Mount

The PTU-D300E-ISM accepts payloads using top or side mounting. Side mounting offers the higher payload rating because it reduces tilt axis torque. The PTU-D300E-ISM itself can be mounted in any orientation; however, consideration should be given to gravity and torque effects depending on PTU orientation and payload mounting orientation and balance.

### Single Side Mount

The PTU-D300E-ISM comes with a single side hub.

**Part Number:** D300E-S-\_\_-000-SS (PTU)  
D300-BKT-LSTD (side bracket)  
D300-BKT-HDS (HD side bracket)

### Dual Side Mounts

Alternatively, you may order the PTU-D300E-ISM with one or two optional side-mount bracket(s), with a permanently mounted top bracket.

**Part Number:** D300E-D-\_\_-000-SS (PTU) and  
D300-BKT-LSTD (bracket)

- **To order a PTU-D300E-ISM with one side-mount bracket:**

Order the PTU with two side hubs (D300E-D-\_\_-000-\_\_) plus one bracket (D300-BKT-LSTD).

- **To order a PTU-D300E-ISM with two side-mount brackets:**

Order the PTU with two side hubs (D300E-D-\_\_-000-\_\_) plus two brackets (D300-BKT-LSTD).

### Heavy payloads (above 20 lbs.):

Order heavy-duty brackets for payloads that exceed 20 lbs.

**Part Number:** D300-BKT-HDS (side)

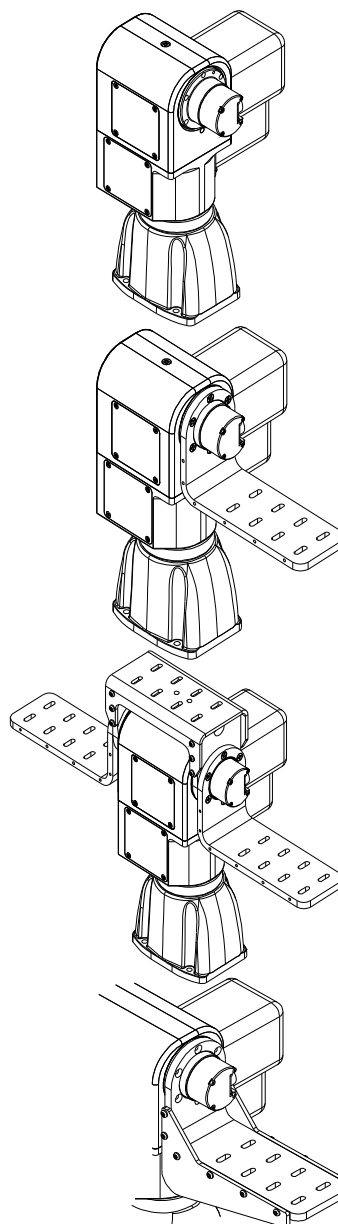

## Bottom Base Connector

The PTU-D300E-ISM may be ordered with the base connector mounted either on the side or bottom of the unit.

**Part Number:** D300E-\_\_-G\_-000-SS (standard) or  
D300E-\_\_-B\_-000-SS (bottom connector)

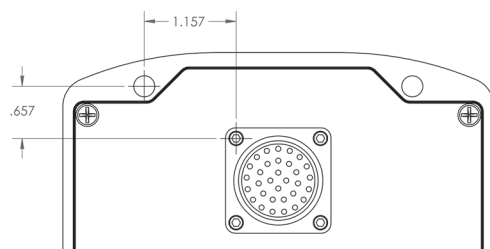

## Slip Ring

The PTU-D300E-ISM includes a slip ring that allows continuous 360° pan rotation.

## Payload Wiring

PTU-D300E-ISM units are equipped with internal pass-through wiring, which provides a 19-pin MIL-C-26402 female receptacle at the top of the PTU near the payload location to connect video, power, and other signals. (The mating connector is provided to facilitate cable construction if needed.) These signals then pass through the PTU, into the connector at the base of the unit, and the cable harness (if purchased). This option allows you to reduce the amount of external cables and eliminate potential damage to external cables.

- **Payload receptacle:** Video 1, Video 2, payload power, and general pass-through lines.
- **Base receptacle:** Video 1, Video 2, payload power, general pass-through lines, PTU control (RS-232, RS-485), and PTU power.

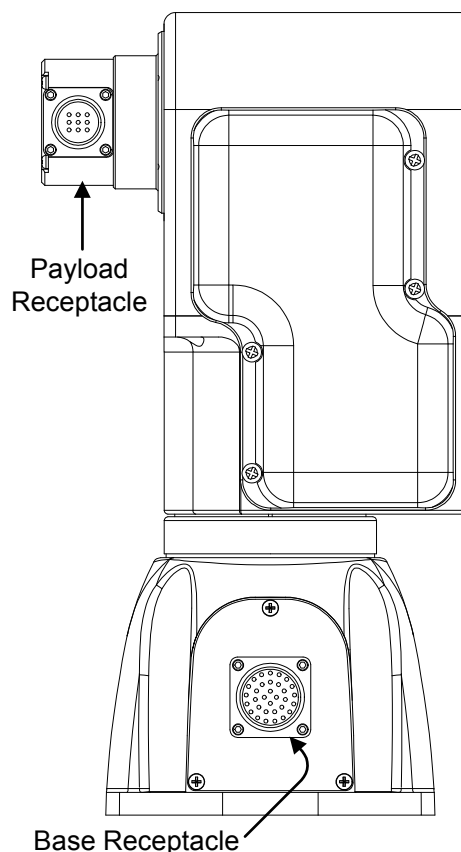

## PL02 Wiring

PL02 allows you to route signals to the payload as shown via 13 dedicated conductors. Includes a mating connector for cable construction.

**Part Number:** D300E-\_\_-G-000-SS

Pass Through Conductors	PL02
Power	3
Video	4
General	6
Total	13
<b>Signals at Payload</b>	
TTL Outputs	3
PTU Host Control	3
CHA/CHB Serial	8
<b>Base Connector</b>	
RS-232 Host Control	NO
RS-485 Host Control	YES
Ethernet/Web	YES

## Range of Motion

The PTU-D300E-ISM has the following standard factory pan and tilt axis limits. Factory limits define the range of motion allowed for an axis when limits are enabled, and that axis cannot travel beyond those limits. The built-in slip ring allows continuous 360° pan-axis movement (see Page 3).

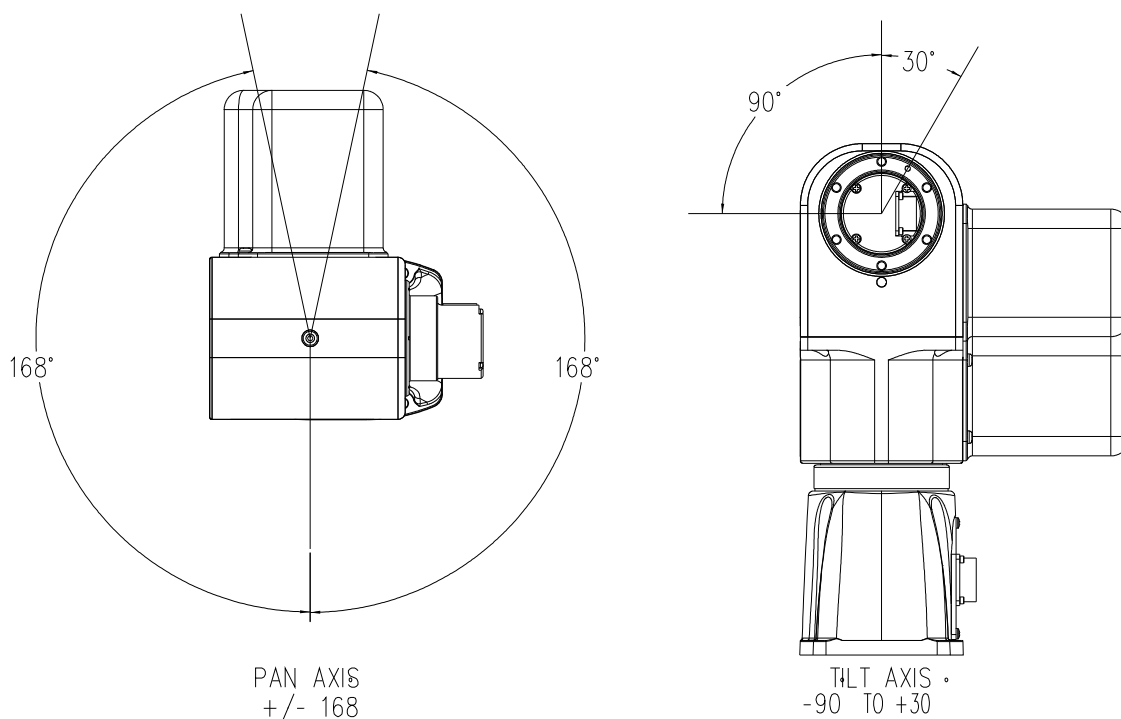

*ISM: ISM-equipped PTUs have a tilt range of +30°/-85° when stabilization is enabled. Disabling stabilization provides the full range of motion listed above.*



*Note: You may special order a PTU-D300E with custom hard stops installed and/or with custom bracket positioning, factory ranges of motion, etc. Please contact FLIR Motion Control Systems, Inc. for assistance.*

### Pan Range Options

**Part Number:** D300E-\_\_-\_\_-000-\*\_

### Tilt Range Options

**Part Number:** D300E-\_\_-\_\_-000-SS (standard)  
TILT-RANGE-180 (+/-90° tilt)

The part number on your PTU-D300E-ISM may vary from what is shown here to reflect any special-ordered custom limits, stops, etc.



*Note: A tilt range of +/-90° is available for PTUs with no top bracket installed. Be sure to note this requirement when placing your order to ensure that factory limits are properly configured. This option is not available for PTUs with the standard top bracket installed.*

## Pan-Tilt Controls

E Series PTUs support serial, Ethernet/web, binary, and joystick control interfaces that provide a wide range of system control architectures. The following options are available:

### ASCII Command Set

Your PTU can be controlled via either the standard built-in serial port (RS-232 or RS-485) or standard built-in Ethernet port (TCP/IP) using simple ASCII commands. (See the E Series *Command Reference Manual*.) This can be done using a terminal program or a custom application.

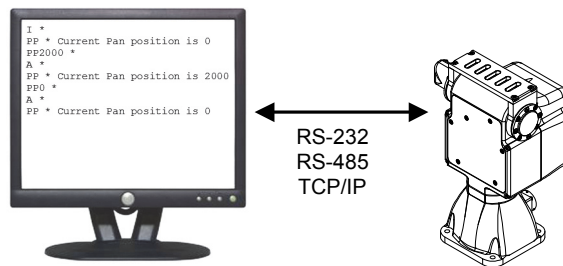

### Ethernet/Web Interface

Your PTU can be controlled via the standard built-in Ethernet port and web interface. The intuitive interface makes configuration and direct control easy using a mouse and direct text entry.

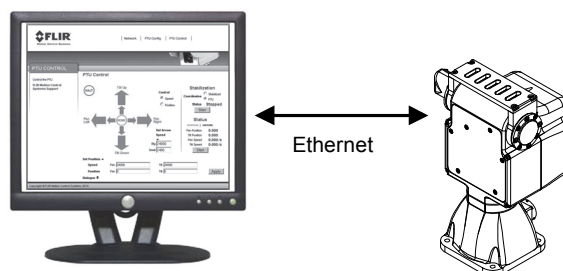

### Pelco D Protocol

E Series PTUs with firmware version 3.1.1 and newer support the standard pan/tilt portions of the proprietary Pelco D protocol. Both the web interface and ASCII commands support various Pelco configuration options.

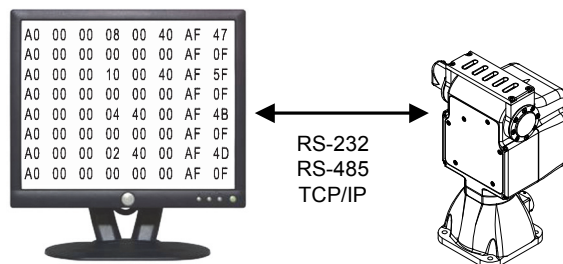

### Software Development Kit (C SDK)

Your PTU can also accept binary commands using the optional C Language Software Development Kit (PTU-SDK), which is provided as ANSI C Source Code that you can compile into your application on most computing platforms (CPU/OS). The binary command format is recommended for high-performance applications such as tracking.

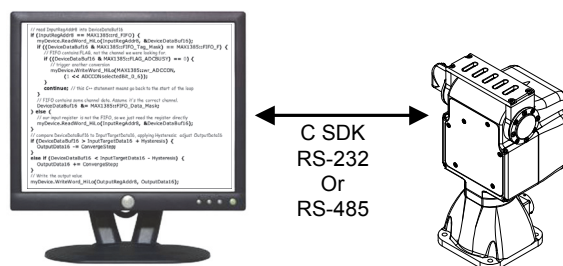

**Part Number:** PTU-SDK

## Gamepad Controller

A USB gamepad controller is available to control a single PTU and up to two VISCA-compatible cameras that are connected to a host computer via a serial connection. The PTU Joystick Control utility is included with E Series PTUs.

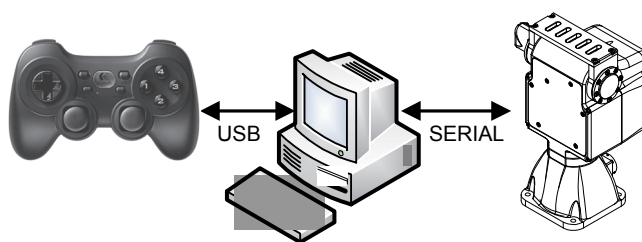

**Part Number:** PT-PSC



*Note: Cameras should be connected to the host PC using a dedicated serial connection for each camera.*

## Rugged Joystick

A rugged joystick (PT-DCJ) is available for direct control of the PTU with no computer required. The PT-DCJ provides proportional joystick control and other inputs via a 25' connection cable. (Please see the *PT-DCJ Datasheet* for details.)

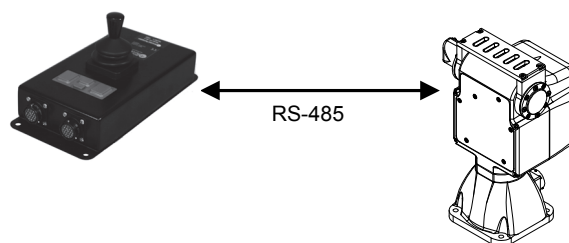

**Part Number:** PT-DCJ (joystick)  
PT-DCJ-E-CABLE (25' DCJ cable)  
PTU-CAB-25BO (DCJ BO cable)

## Accessories

The following accessories may be ordered for your E Series PTU. These accessories simplify system prototyping and fielding.

### Breakout Cables

The breakout cable connects to the 32-pin base connector (MIL-C-26482) on the PTU and terminates to standard connectors for power, serial communication, Ethernet, and payload signals. The terminating connectors are:

Power (DIN), 2x video (composite), RS-232 (DB-9, female), RS-485 (RJ11), Ethernet (RJ45), and payload pass-through conductors. Available in 25', 50', and 100' lengths.

**Part Number:** PTU-CAB-E-25BO (25') or  
PTU-CAB-E-50BO (50') or  
PTU-CAB-E-100BO (100')

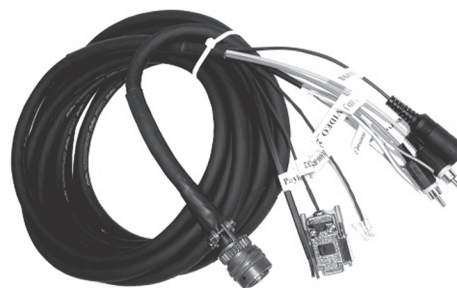

# PTU-D300 E Series (ISM) Configuration Guide

---

## Power Supply

PTU power supply unit. 30VDC output, 110/220VAC input.

Dimensions: 3.44"W x2.01"Hx7.61"L.

**Part Number:** PTU-APS-30V-NA (North America) or  
PTU-APS-30V-EC (Europe)



*Note: Input voltages under 30V can reduce the maximum speed of the unit by an amount that is proportional to the voltage difference.*



## Starter Kit

The PTU starter kit includes one power supply (PTU-AC-APS-30V), one 25' breakout cable (PTU-AC-CAB-25BO), and one USB to RS-485 adapter cable (PTU-CONV-USB-RS485).

**Part Number:** PTU-KIT-E-STR-NA (North America) or  
PTU-KIT-E-STR-EC (Europe)



*Note: Input voltages under 30V can reduce the maximum speed of the unit by an amount that is proportional to the voltage difference.*

## Mating Connector

Mating connector for the 32-pin base (MIL-C-26482) and 19-pin payload (MIL-C-26402) PTU connectors. Use this to make custom PTU and/or payload cables.

**Part Number:** PTU-CAB1-19PMILC (19-pin payload) or  
PTU-CAB3-32PMILC (32-pin base)



*Note: Each E Series PTU with a wiring option (PL01, PL02, or PL17) includes one (1) 19-pin mating connector (PTU-CAB1-19PMILC).*



## RS-485 to RS-232 Converter

Bi-directional module that converts signals from RS-232 to RS-485. Includes power supply, coupler, and cable.

**Part Number:** PTU-CONV-RS485C



## USB to RS-485 Adapter Cable

Cable that converts USB to RS-485 serial connections.

**Part Number:** PTU-CONV-USB-RS485

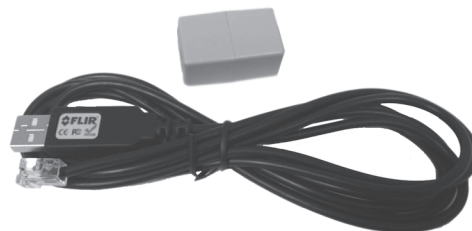

## Rugged Joystick and Cable

This rugged joystick allows PTU control without a host computer. Cable ordered separately.

**Part Number:** PT-DCJ (joystick) and  
PT-DCJ-E-CABLE (25' DCJ connection cable) or  
PTU-CAB-25BO (19-pin breakout cable for DCJ)



## E Series PL01/PL02 Adapter Cable

These cables allow you to connect an E series PTU to an existing D series setup without rewiring, except that the Ethernet/web connection will not be available. Make sure to order the correct cable for your wiring setup (PL01 or PL02).

**Part Number:** PTU-CAB-E-AD-PL01 (PL01) or  
PTU-CAB-E-AD-PL02 (PL02)



**Your authorized FLIR distributor:**

**MOVITHERM**  
advanced thermography solutions

15540 Rockfield Blvd, Suite C-110  
Irvine, CA 92618

Phone: (949) 699-6600

Fax: (949) 699-6601

Email: [info@movitherm.com](mailto:info@movitherm.com)

<http://www.movitherm.com>